

Ingeniería Civil

*¡Ventaja para los
expertos de la obra!*



BETEK

Avanzando!



Programa de herramientas

Página

Barras para soldar			7 – 9
Barras de recambio rápido			10 – 12
Dientes soldados			12
Dragon Tooth			13
Dientes planos			14 – 16
Pilotos			17
Brocas de vástago redondo	Sistema de vástagos	Ø 11,3 mm / 0,44", 13 mm/0,52"	18
Brocas de vástago redondo	Sistema de vástagos	Ø 14 mm / 0,55", 18,7 mm/0,74"	19
Brocas de vástago redondo	Sistema de vástagos	Ø 19,4 mm / 0,76"	20
Brocas de vástago redondo	Sistema de vástagos	Ø 25 mm / 1"	21 – 22
Brocas de vástago redondo	Sistema de vástagos	Ø 38/30 mm - 1,5/1,18"	23 – 24
Conexiones atornilladas			25
Dientes planos para Fresa Hidráulica			27
Perforación horizontal dirigida (PHD)			28 – 30
Protección contra el desgaste			31

En las ilustraciones de herramientas de las páginas siguientes encontrará las siguientes informaciones:

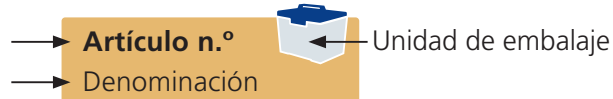

Dimensiones: mm / pulgadas

Instrucciones de soldeo:

www.betek.de/es/productos/perforacion-de-cimientos-informacion.html

SERVICE:

Alemania: info@betek.de
Tel.: +49 (0) 74 22 / 5 65-591



Barras para soldar

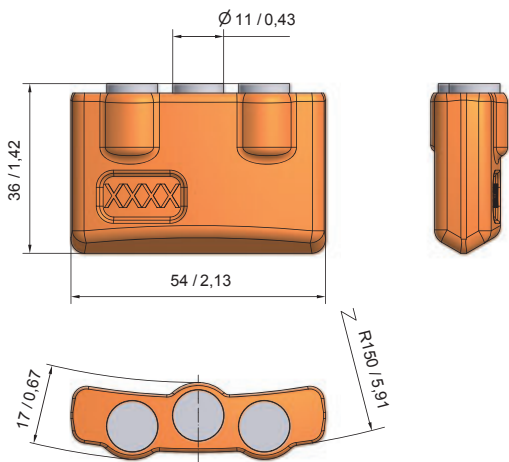

BA12
BA55-17/11/R 50

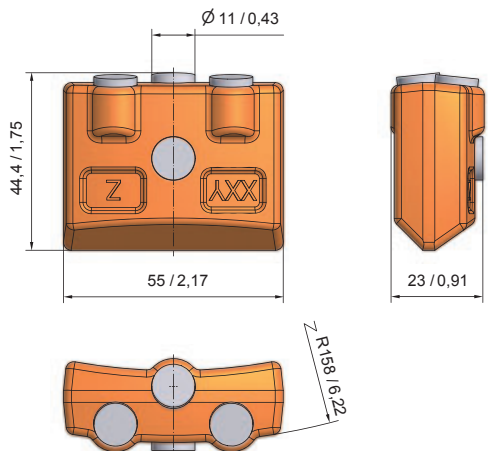

BA13
BA55-22 50

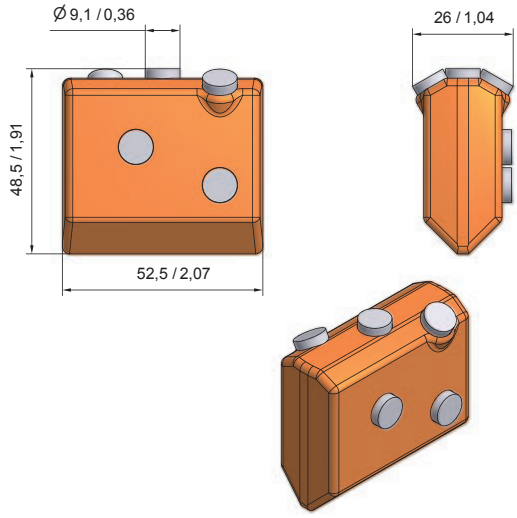

BA10
BA50-26.5 50

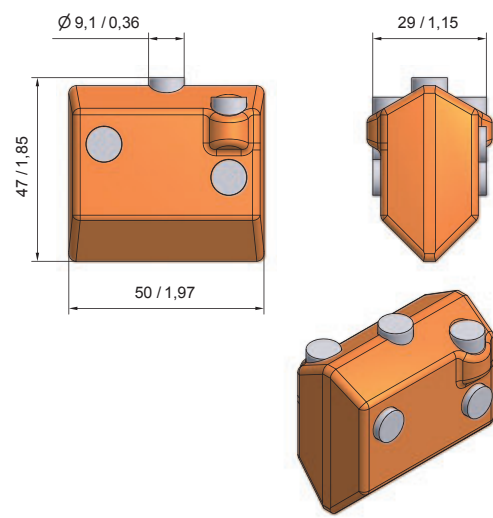

BA09
BA50-29 30

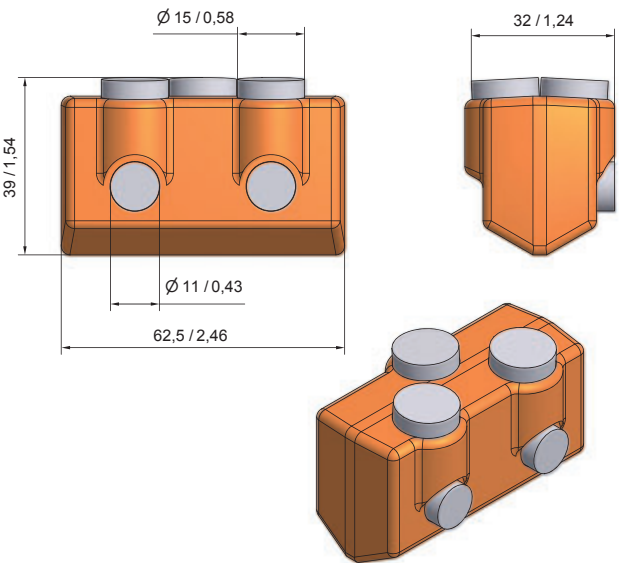

BA32
BA60-32/2 20

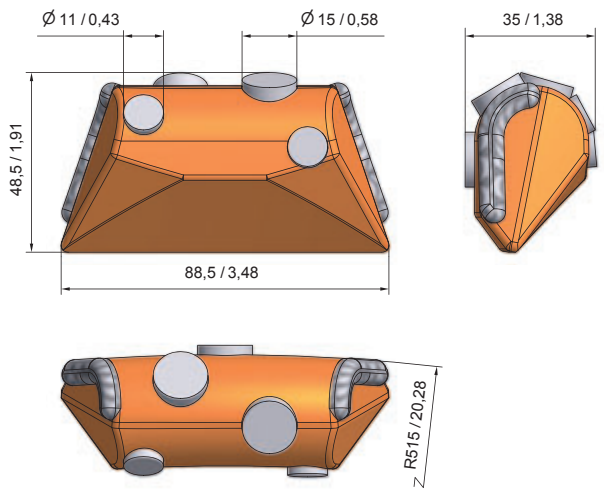

BA01
BA90-35 25

Barras para soldar

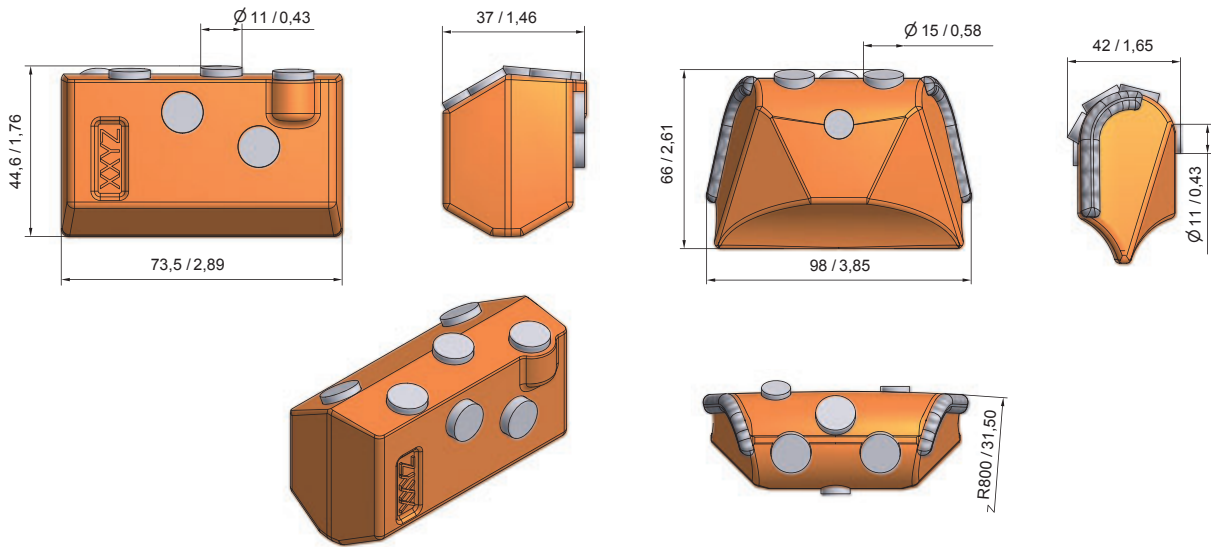

BA04
BA70-38

20

BA24
BA90-42

15

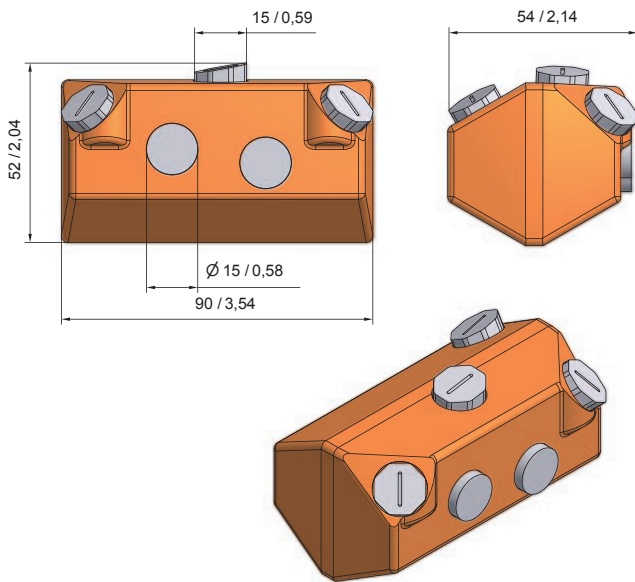

BA19
BA90-54

10



Barras para soldar

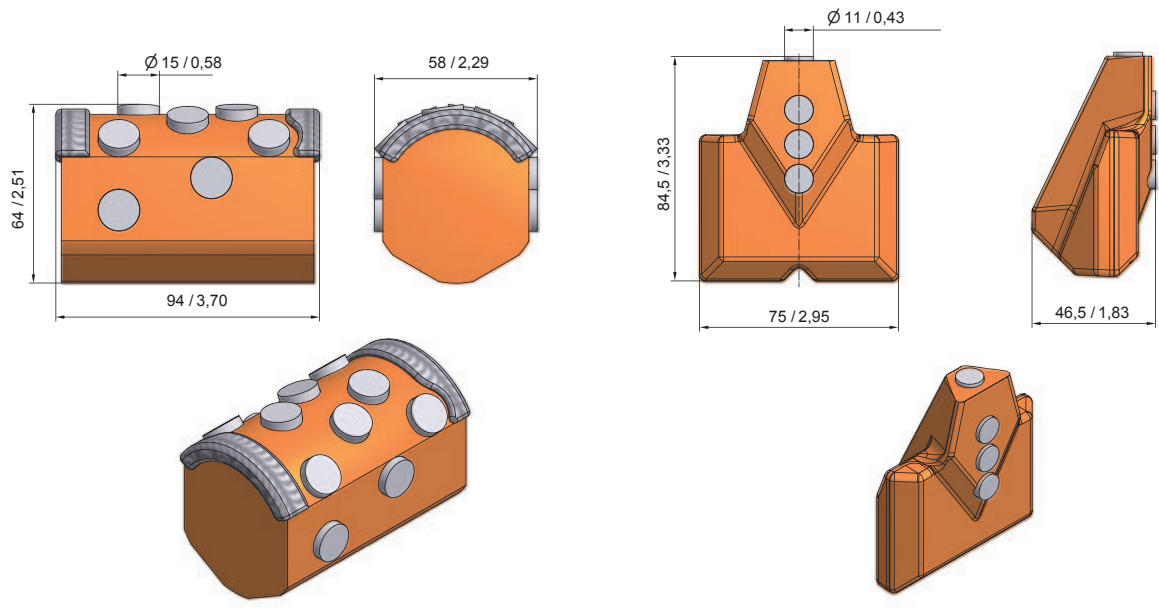

BA28
BA90-58/3

8

BFZ26
BFZ83x75x45/1

15

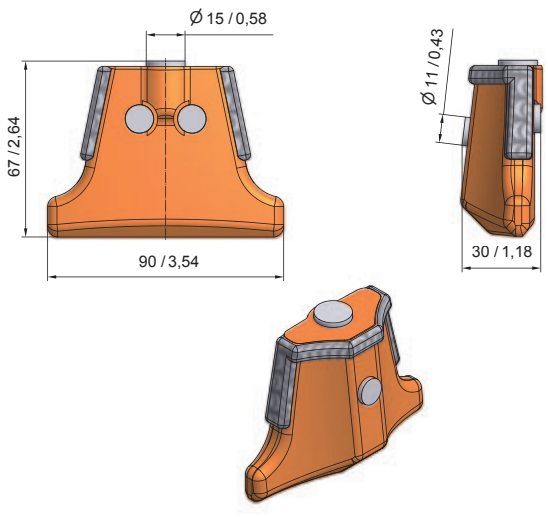

BFZ72 / B
BFZ65x90x30

25



Barras de recambio rápido 40 mm/1,58" grosor de la pared encamisado

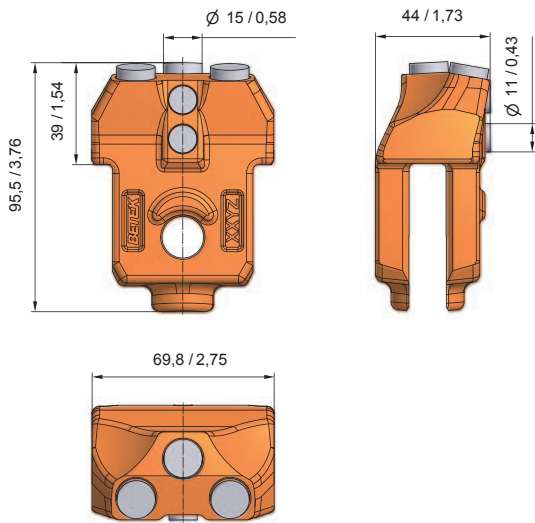

BA47

BA105x70x40

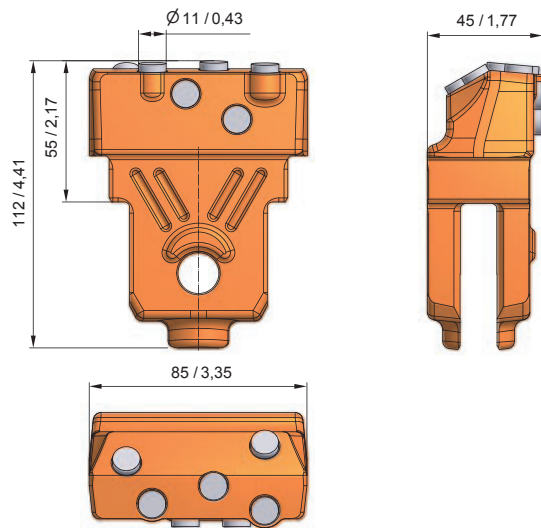

BA50

BA112x85x40

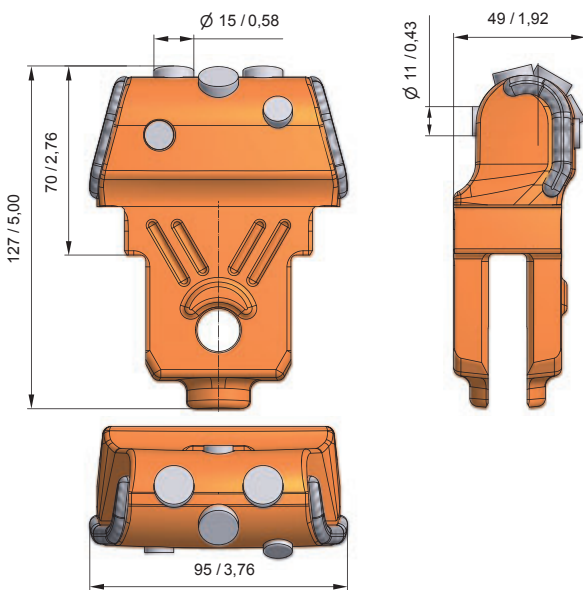

BA51

BA 127x90x40

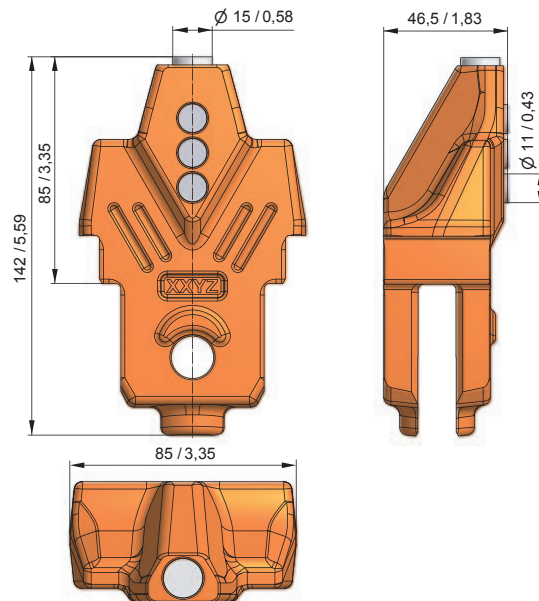

BA52

BA 142x85x40

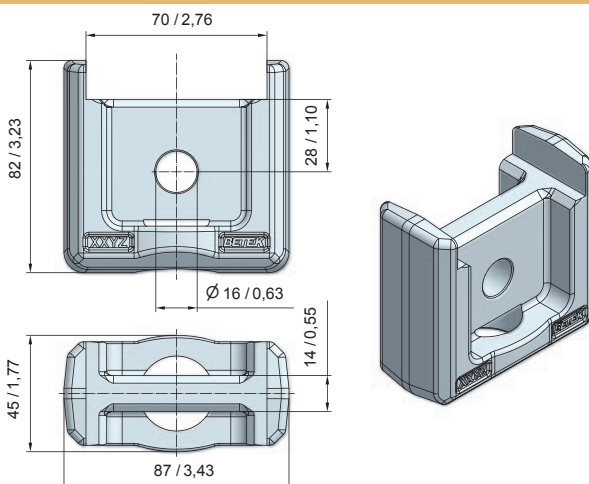

BHA04

BHA87x82x38



SPH73

Barras de recambio rápido 50 mm/1,97" Grosor de la pared encamisado

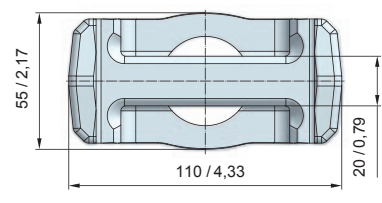
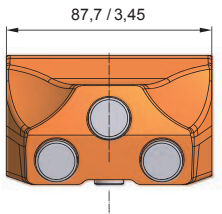
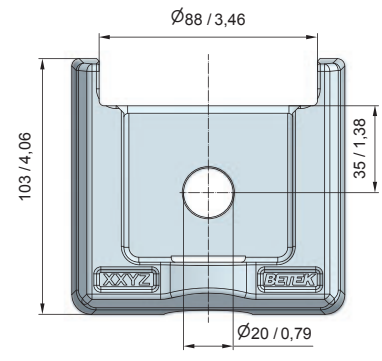
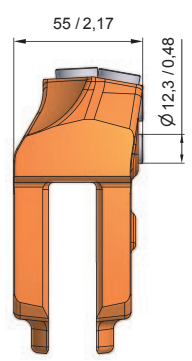
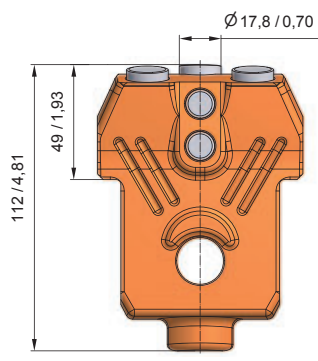

BA53
BA122x88x50



BHA05
BHA110x103x50



Barras de recambio rápido

Para un mayor avance de la perforación, gracias a una nueva geometría de corte y un cambio más rápido en el lugar de obras.

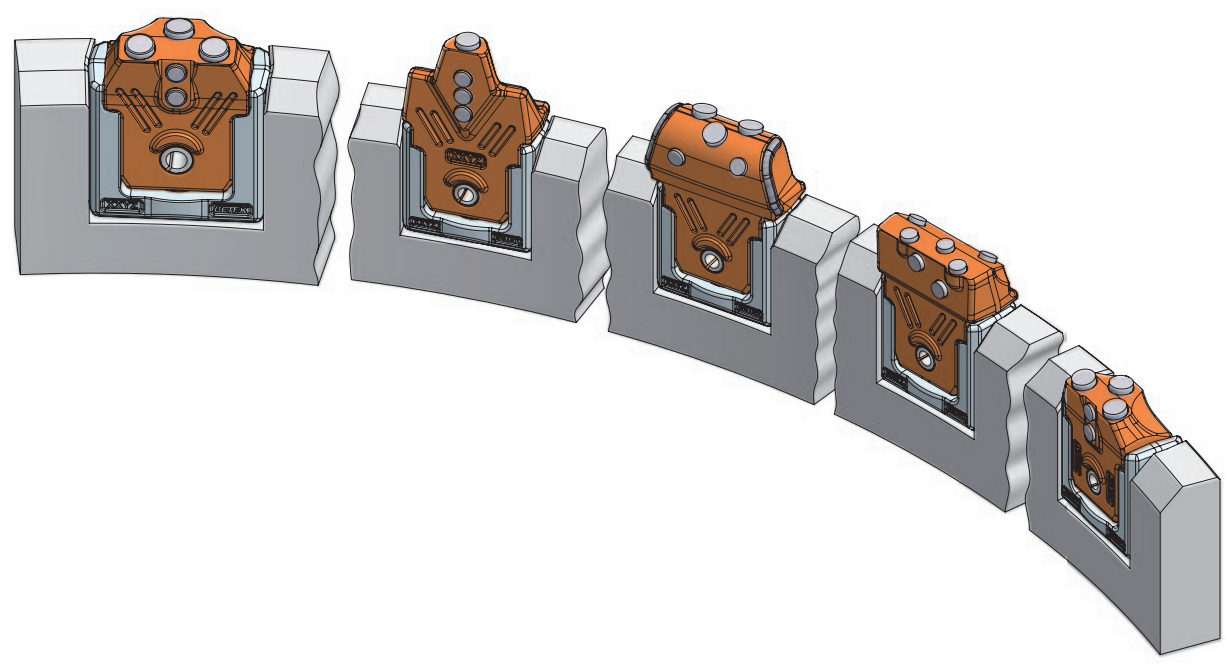

Barras de recambio rápido 40 mm/1,58" grosor de la pared encamisado

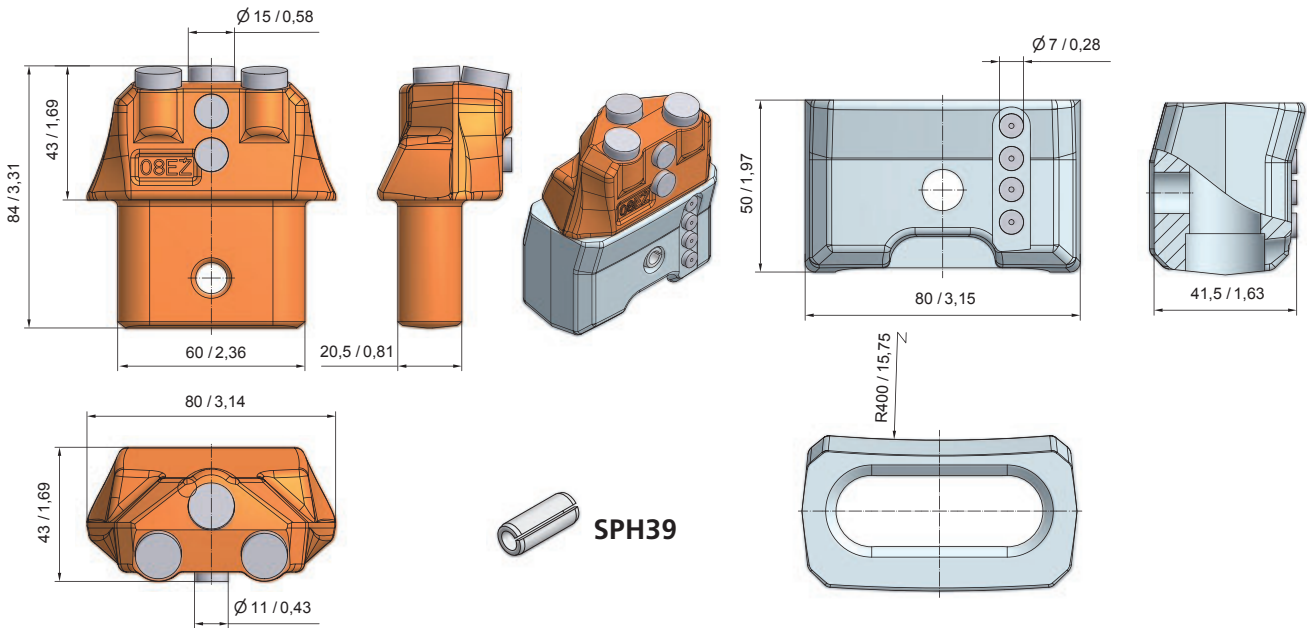

BA46
BA80-31

15

BHA02
BHA60/2

20

Dientes soldados

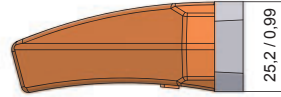
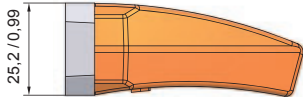
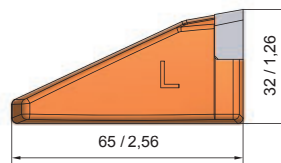
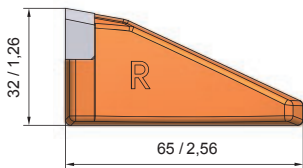

BFZ25R
BFZ25-R

50

BFZ25L
BFZ25-L

50

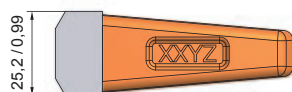
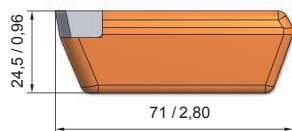

BFZ96
BFZ71x25

50

Dragon Tooth

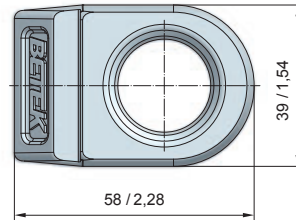
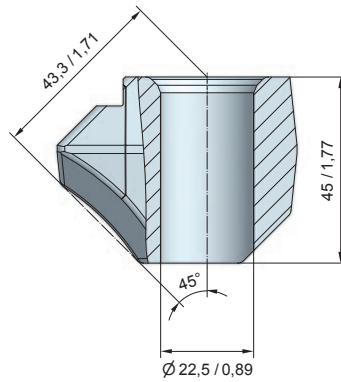
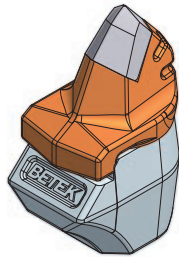
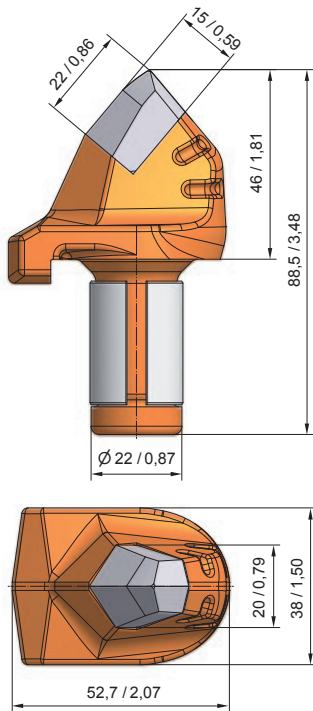
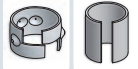

BFR07
BFR 46-22



BHR133
B10/22-F

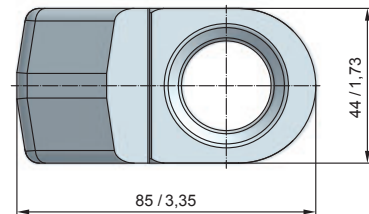
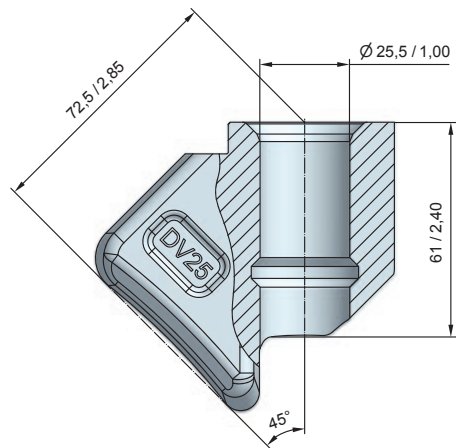
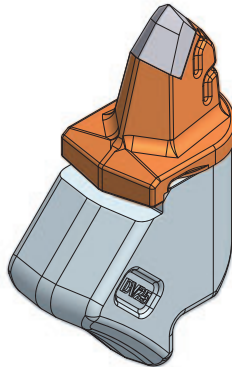
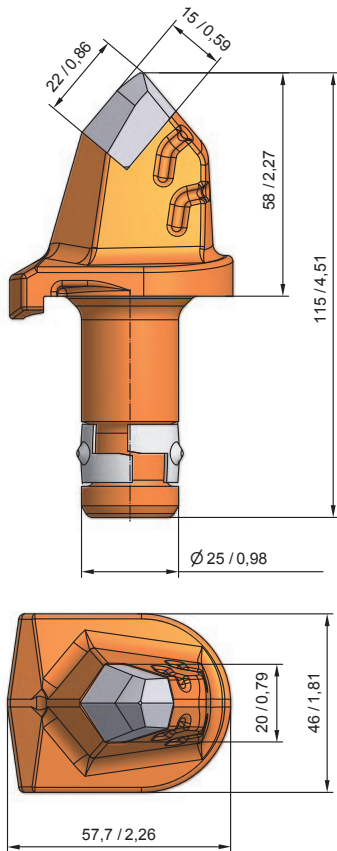

BFR08
BFR58-25



BHR184
DV25-F



Dientes planos

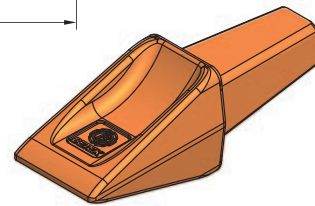
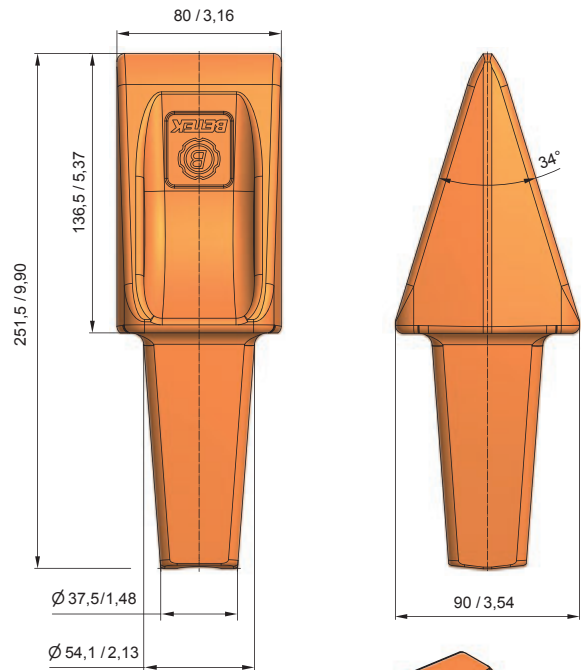
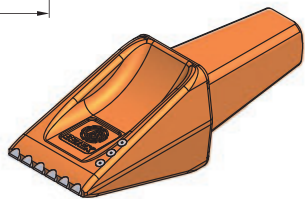
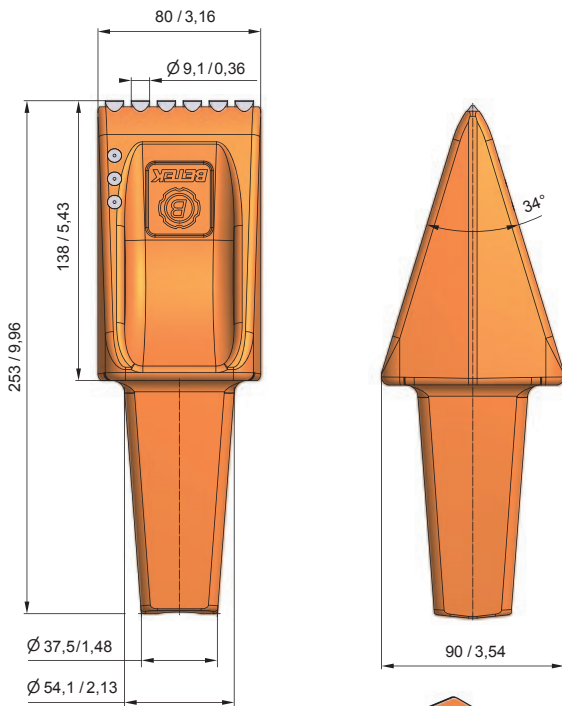

BFZ317
BFZ80-B



BFZ79
BFZ80 OHM

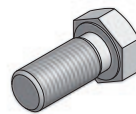
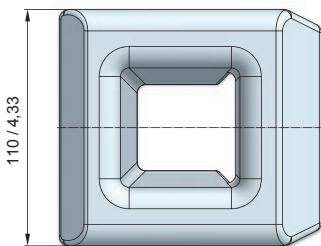
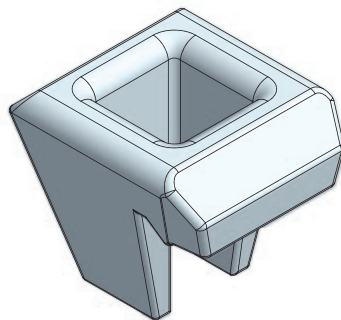
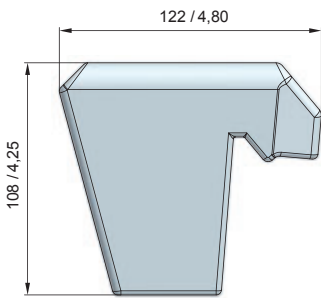

S1102

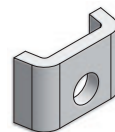

S1103

BHR73
BHZ80/2



Dientes planos

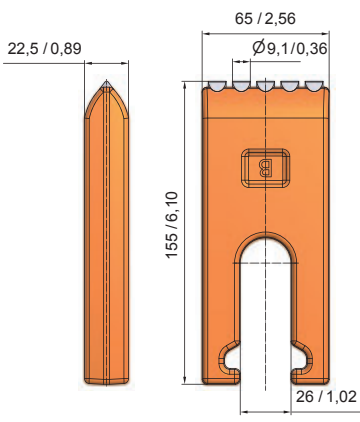

BFZ65HM
BFZ65/2

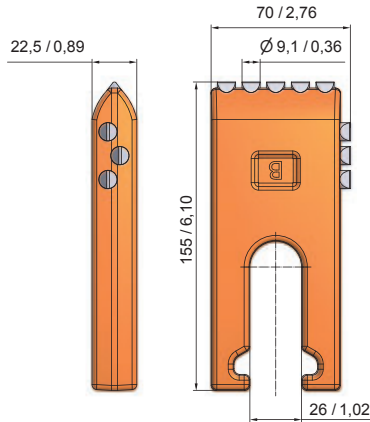

BFZ02
BFZ65/3

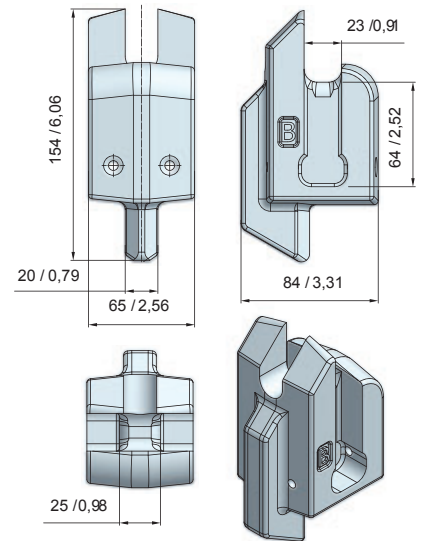

BHF02
B65-22

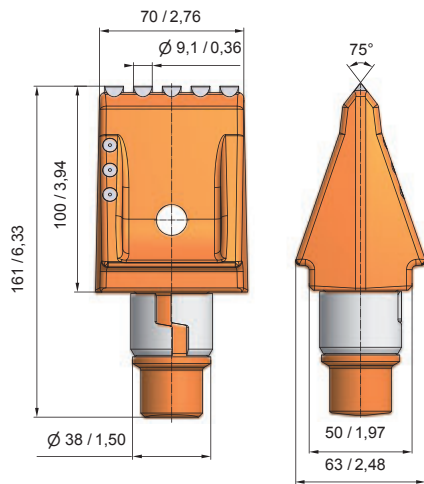

BFZ162
BFZ100x70/2

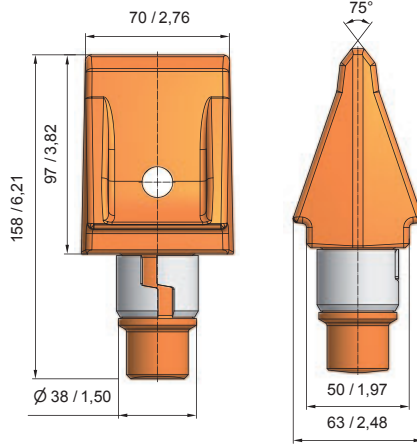

BFZ69
BFZ100x70

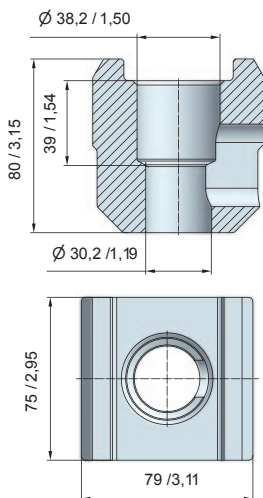

BHR112
B75

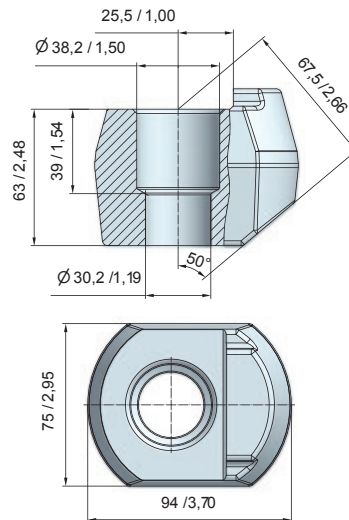

BHR39
B48



Dientes planos

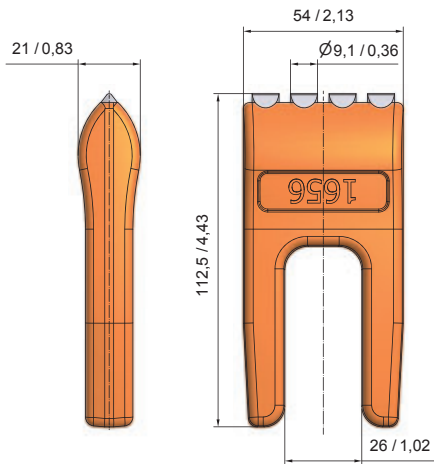

BFZ05N
BFZ1656N

25

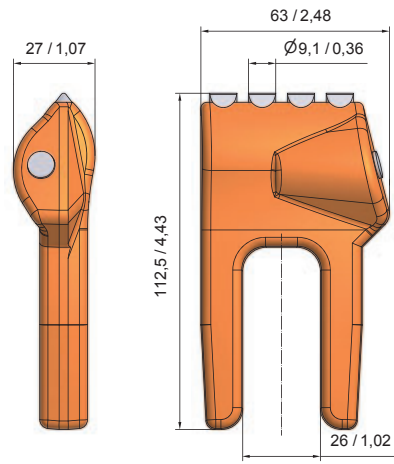

BFZ198N
BFZ1658N

20

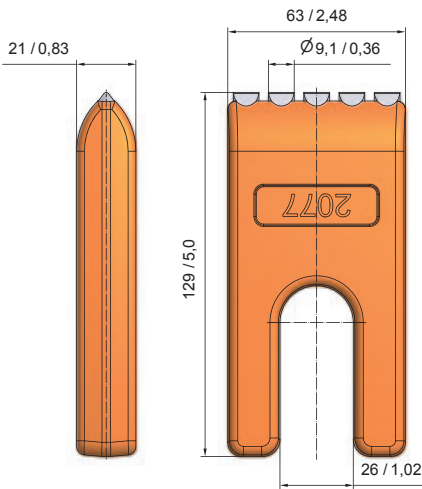

BFZ200N
BFZ2077N

15

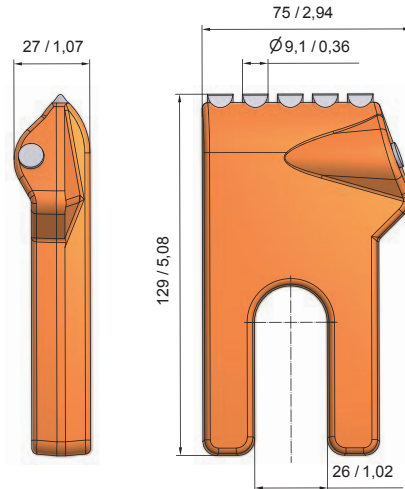

BFZ218
BFZ2078

15

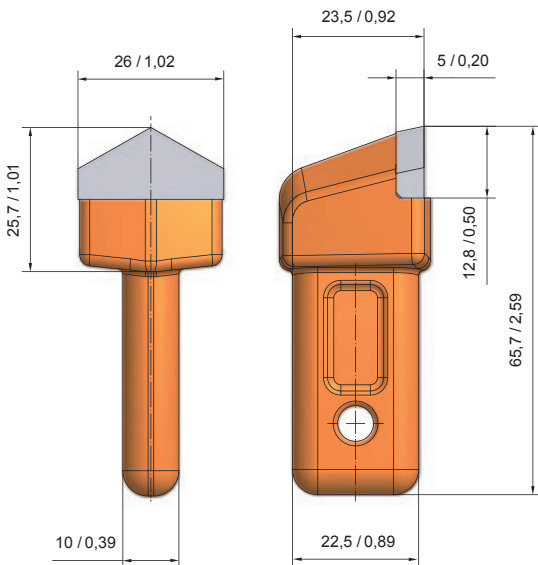

BFZ272
BFZ67x30x26

100

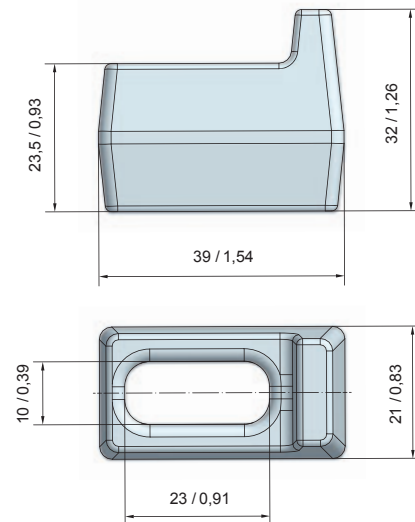

BHZ24
BHZ39x32x21

100

Pilotos

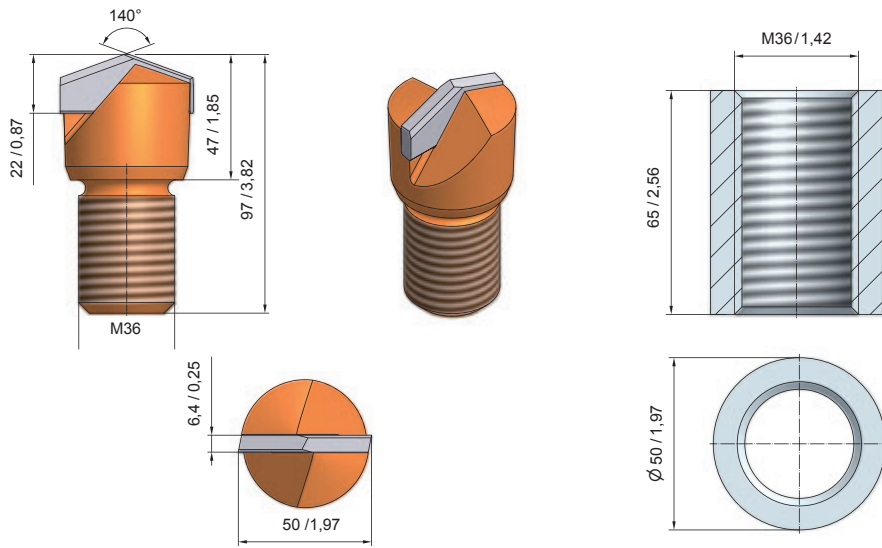

BP04 20 **BPH01** 10
BP51/M36-HD3 GH-M36

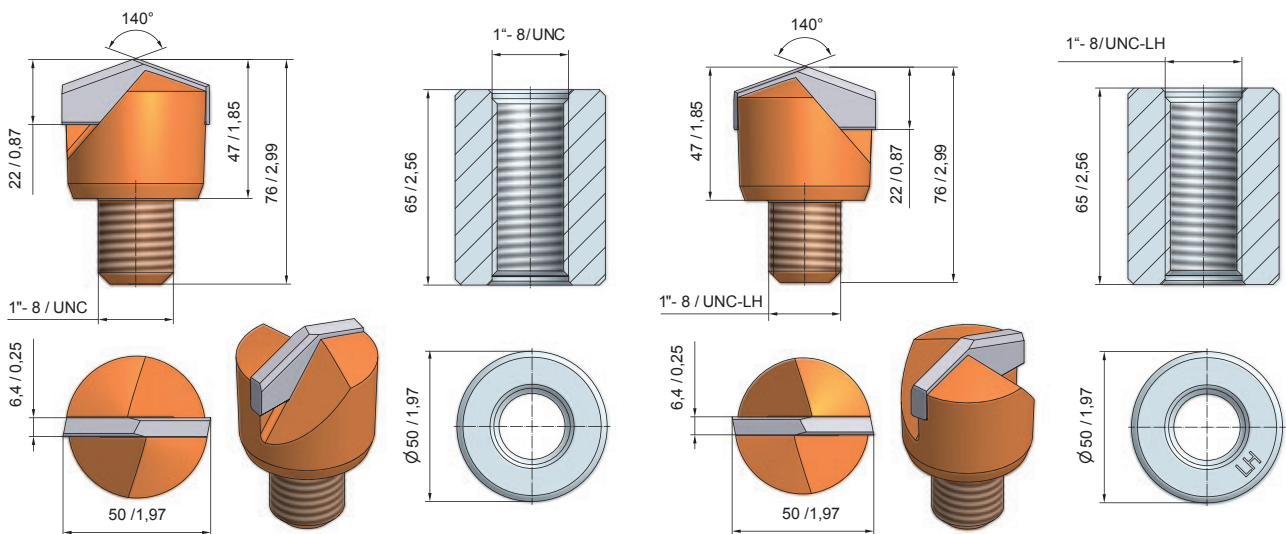

BP01 20 **BPH02** 10 **BP10** 20 **BPH03** 10
BP51/1"-HD3 GH-1" BP51/1"-HD3/LH GH-1"LH

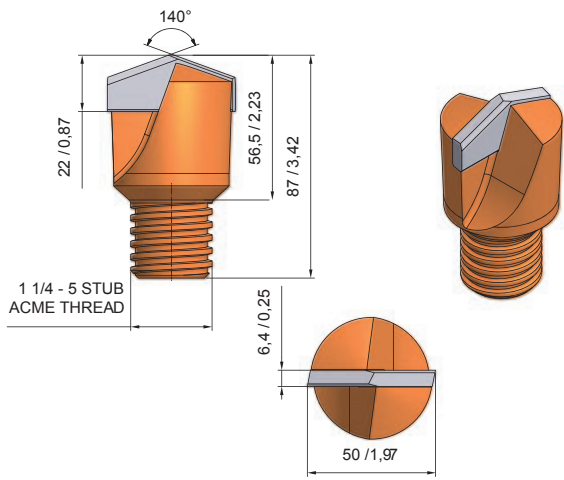

BP51 20
BP51x87



Sistema de vástagos Ø 11,3 mm/0,44"

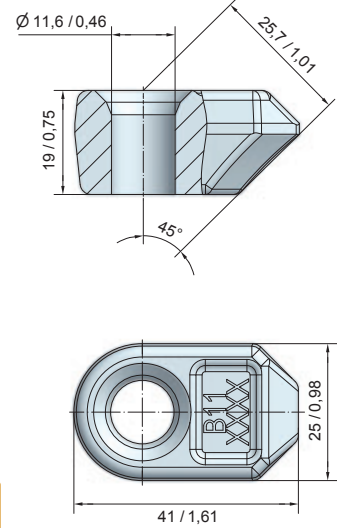
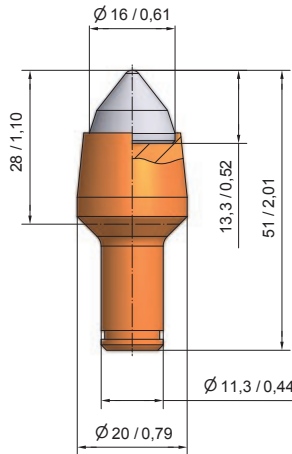
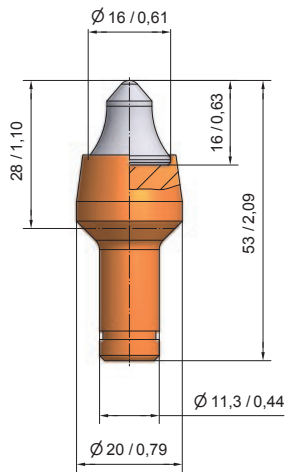
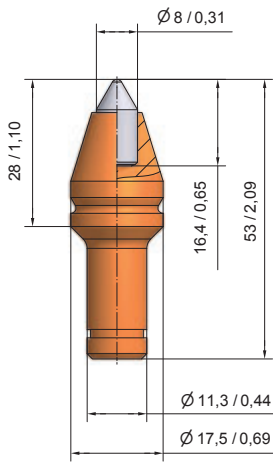

BM11



BM 8-11.3

BM10



BM 4-11.3

BM46



BM 3-11.3



SR54

BHR03



B 11

Sistema de vástagos Ø 13 mm/0,52"

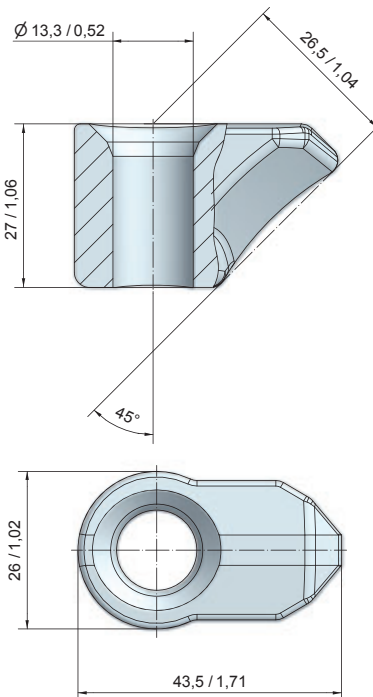
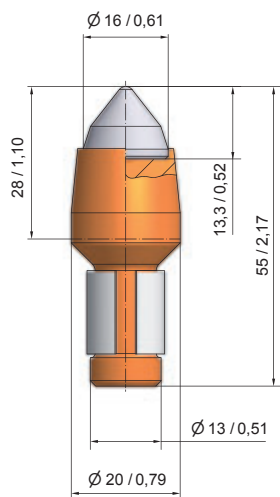
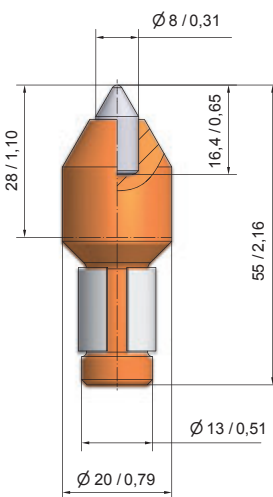

BM34



BM 8-13/H

BM62



BM3-13/H

BHR47



B13

Sistema de vástagos Ø 14 mm/0,55"

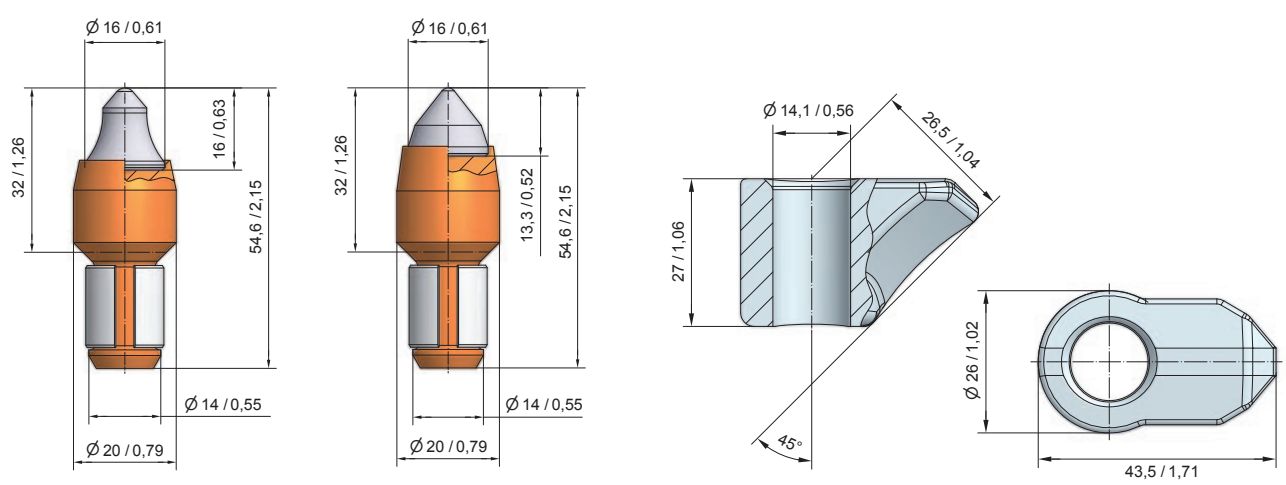

BM55
BM 4-14/2

200

BM60
BM 3-14/H

200

BHR109
B14

150

Sistema de vástagos Ø 18,7 mm/0,74"

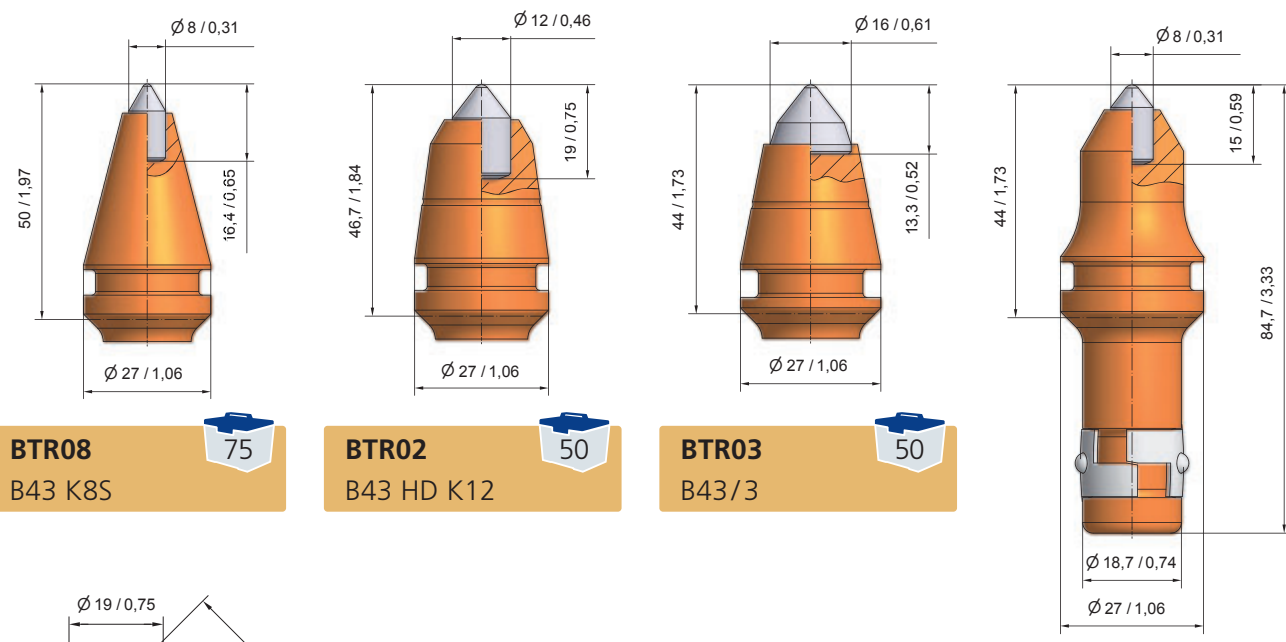

BTR08
B43 K8S

75

BTR02
B43 HD K12

50

BTR03
B43/3

50

BTR01
B43K8

50

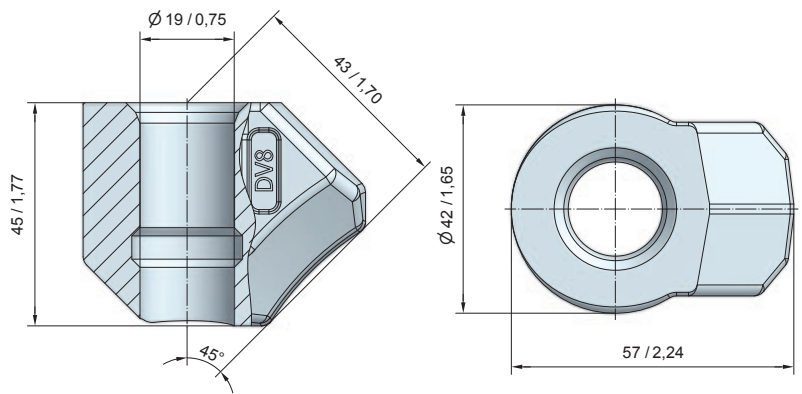

BHR20
DV 8

40

Sistema de vástagos Ø 19,4 mm/0,76"

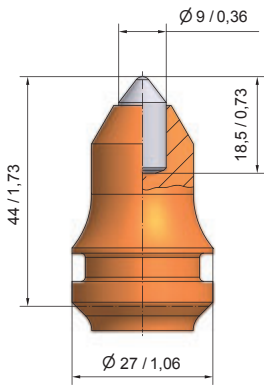
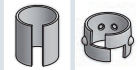

BSK15
B1K9-K

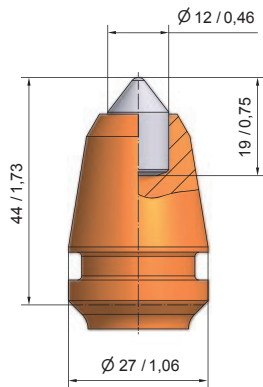

BSK17
B1HDK12-K

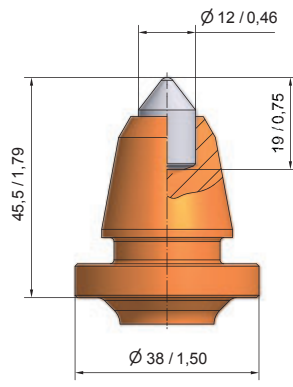

BSK21
B1-12/38-K

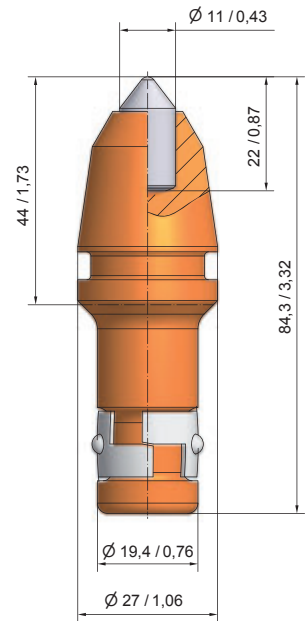

BSK16
B1HDK11-K

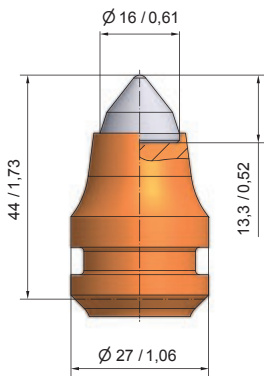

BSK12
B3-K

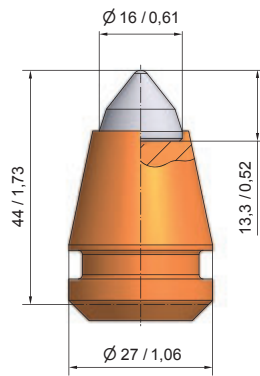

BSH09
B3

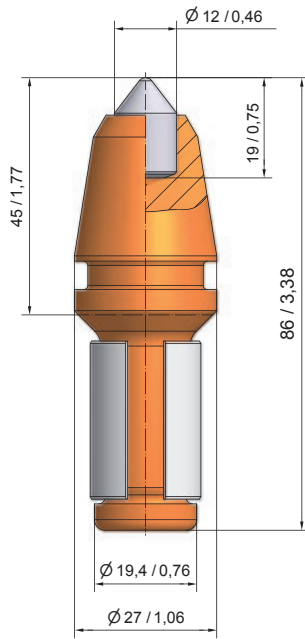

BSH05
B1HDK12

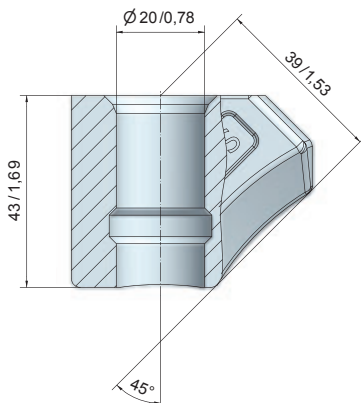

BHR164
DV9-S

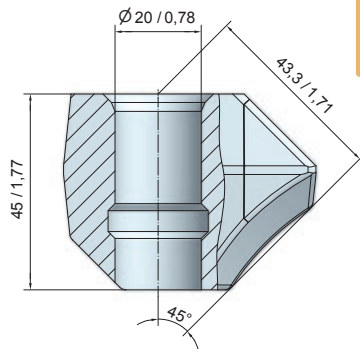

BHR07
DV 9

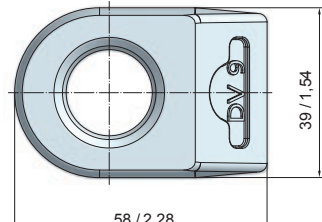
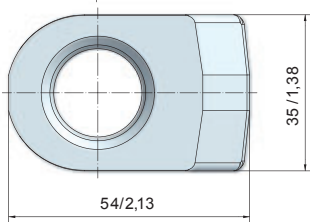

Sistema de vástagos Ø 25 mm / 1"

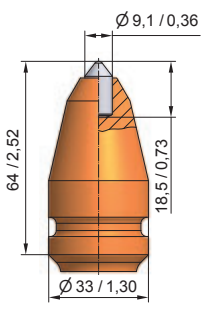

BTK01
B40 K9

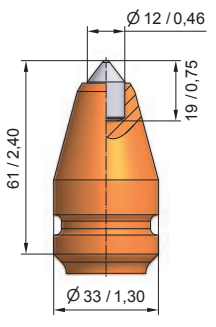

BTK03
B40 HD K12

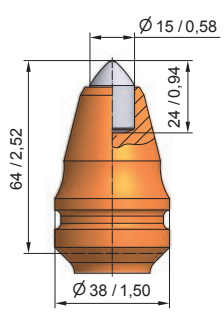

BTK10
B40 HDS

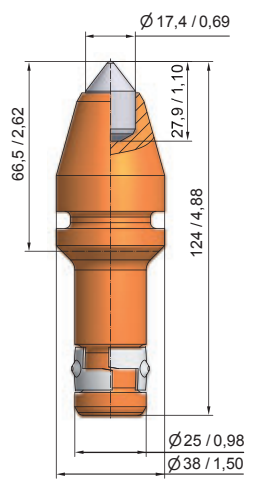

BTK70
B40K17.5

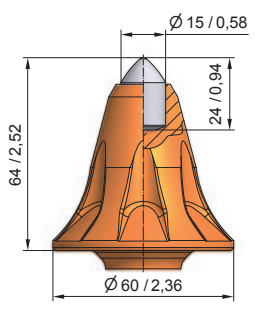

BTK81
B40 HDS/60

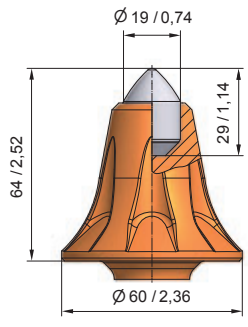

BTK89
BG25K-19.6064

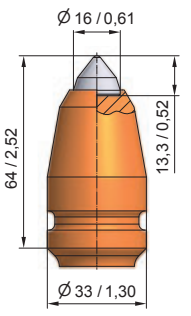

BTK16
B40/3

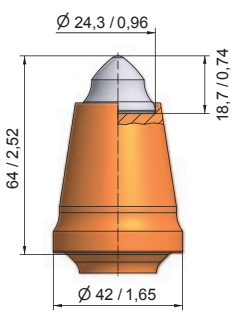

BTK87
B40/9

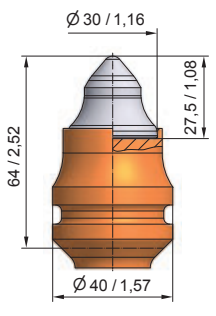

BTK23
B40 HBL

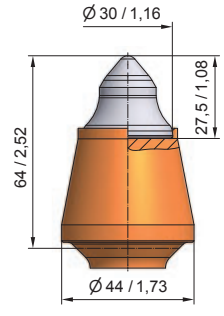

BTK26
B40-J1-HBL





Sistema de vástagos Ø 25 mm / 1"

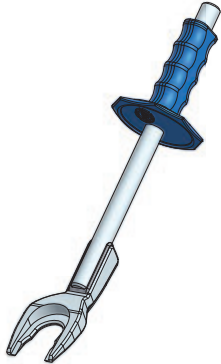
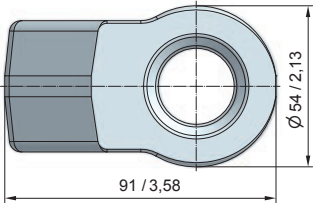
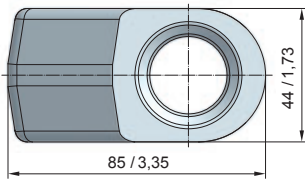
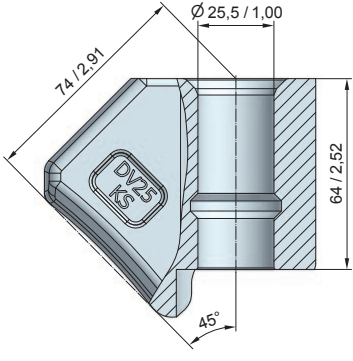
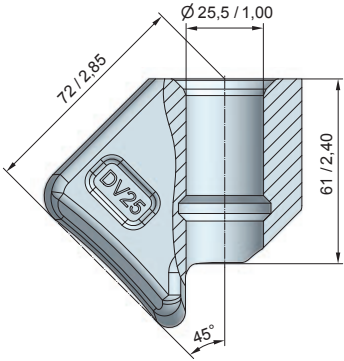

BHR31
DV 25

15

BHR121
DV 25 KS

10

BZ22
Tirador de broca



Sistema de vástagos Ø 38/30 mm - 1,5/1,18"

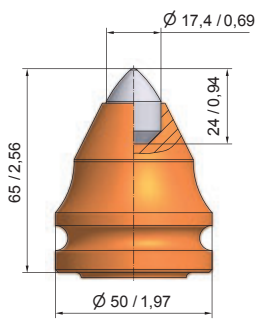

BKH140
B47K17.5-H/2

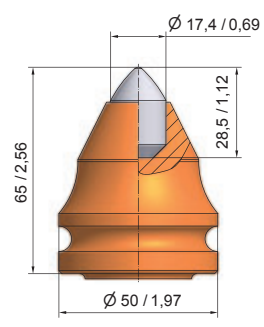

BKH28
B47K17.5-H

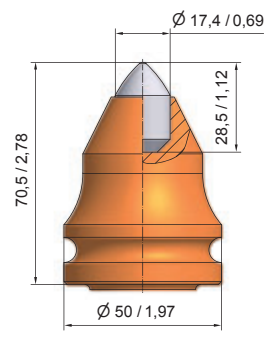

BKH80
B47K17.5LK70-H

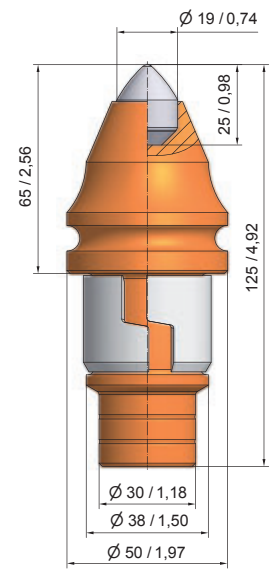

BKH83
B47K19-H/2

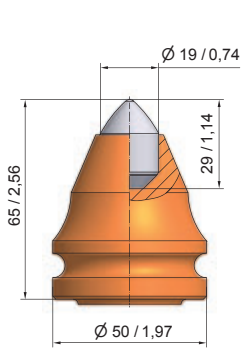

BKH40
B47K9-H

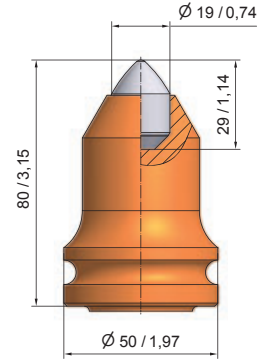

BKH41
B47K19LK80-H

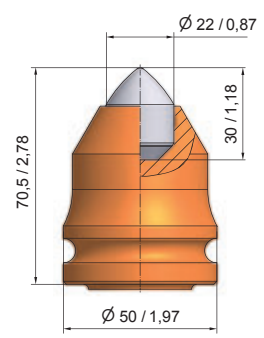

BKH85
B47K22-H/2

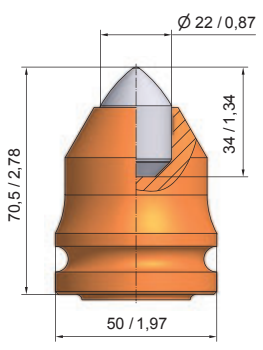

BKH47
B47K22-H

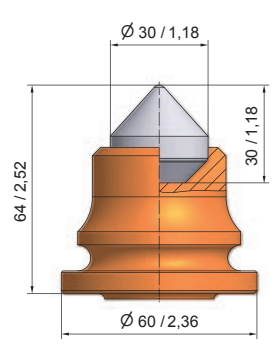

BKH81
B47K30/60-H

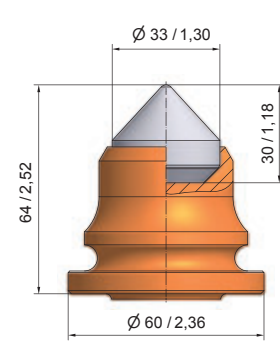

BKH84
B47K33/60-H

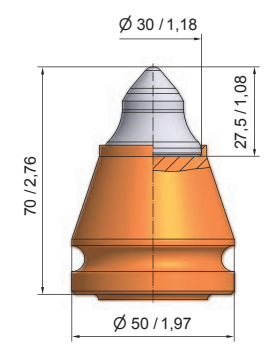

BKH73
B47K30LK70-H



Sistema de vástagos Ø 38/30 mm - 1,5/1,18"

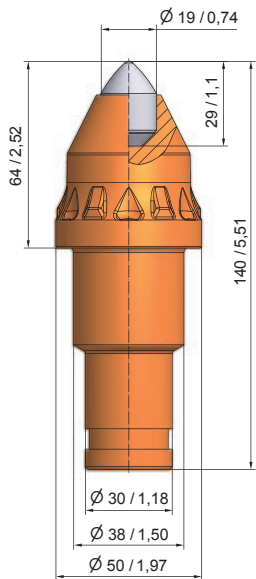

BKS154 10
BS38W-19.5064

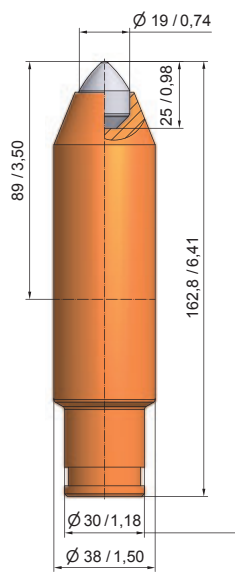

BKS186 15
BS38W-19.3889

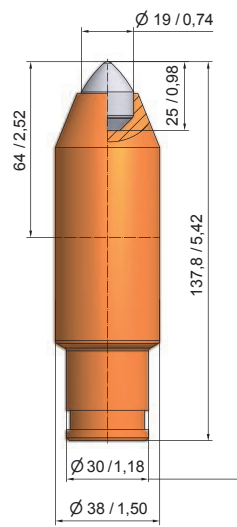

BKS187 15
BS38W-19.3864

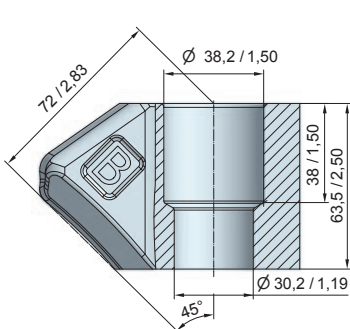

BHR38 10
B43H

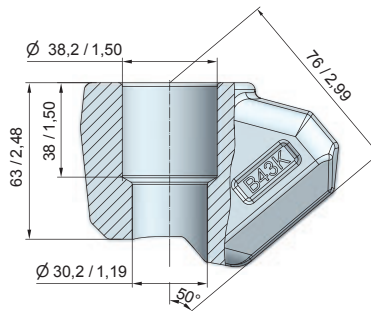

BHR113 6
B43K

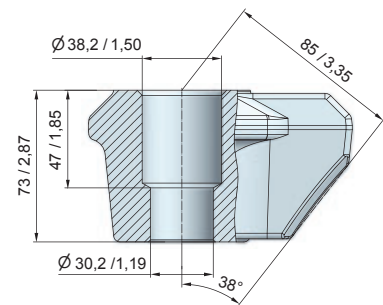

BHR77 5
B320

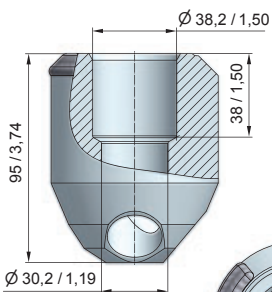
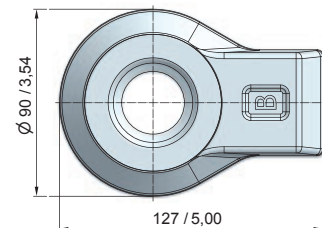
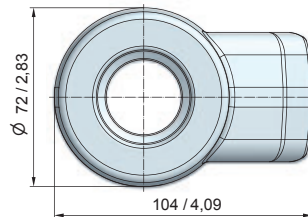
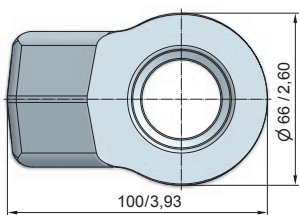

BHR163 6
B76/P

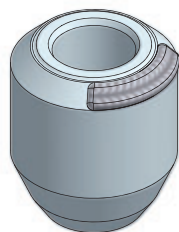
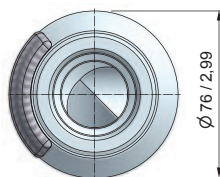

BZ12
Tirador de broca



BZ12
Tirador de brocas
incluyendo disco de cobre

Conexiones atornilladas

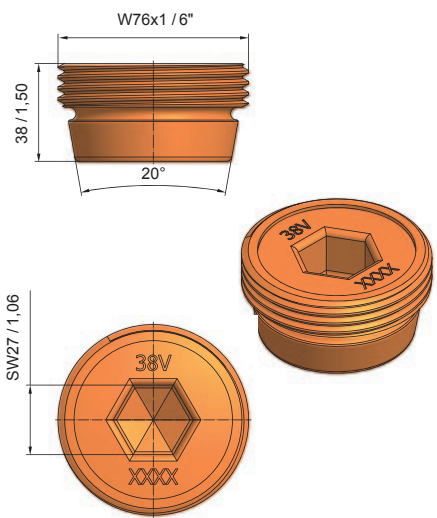

BRV08 15
BRV75/38LV

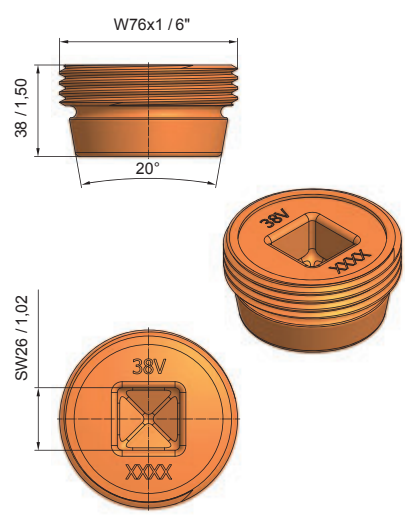

BRV10 15
BRV75/38LV/4

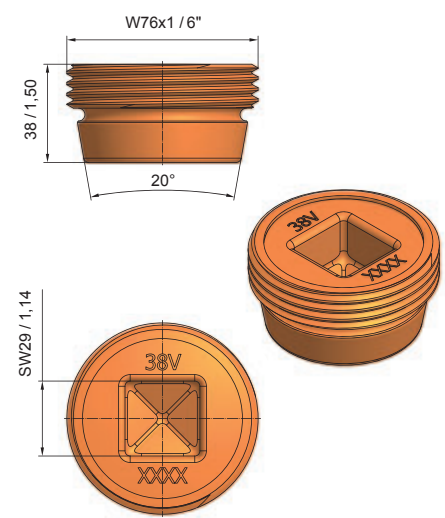

BRV23 15
BRV75/38LV/4/29

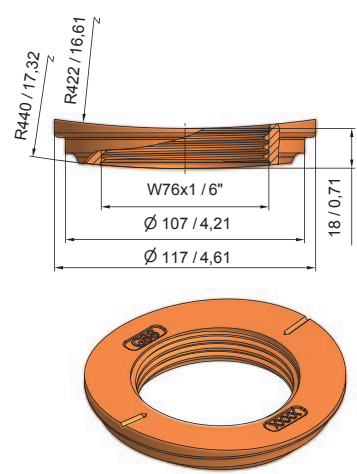

BRV02 15
BRV-G88/L

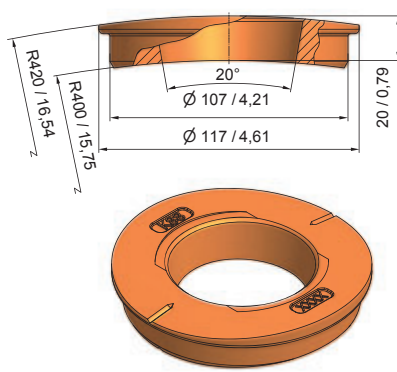

BRV03 15
BRV-K88/L

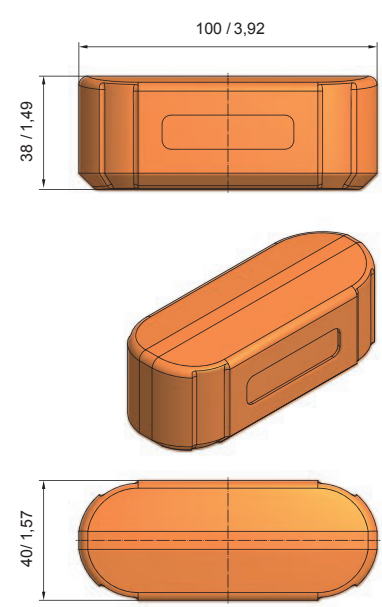

BRV32 15
BRV-AK



BRV34
BRV SW26



BRV35
BRV SW29

Denominación	Utilización/ Información	Artículo n.º
Conexiones atornilladas con un grosor de pared de hasta 30 mm.		
BRV-G46-14	d=460	BRV19
BRV-K46-14	d=460	BRV18
BRV60/29/4	–	BRV20
Conexiones atornilladas con un grosor de pared de hasta 40 mm.		
BRV-G64/B	d=620 - 640	BRV04
BRV-K64/B	d=620 - 640	BRV05
BRV-G64/L	d=620 - 640	BRV14
BRV-K64/L	d=620 - 640	BRV15
BRV-G88/L	d=880	BRV02
BRV-K88/L	d=880	BRV03
BRV-G118/L	d=1180	BRV06
BRV-K118/L	d=1180	BRV07
BRV-G150/L	d=1500 - 1800	BRV12
BRV-K150/L	d=1500 - 1800	BRV11
BRV-G80-100-B	d=800 - 1000	BRV30
BRV-K80-100-B	d=800 - 1000	BRV31
BRV75/38LV	(6kt.SW27)	BRV08
BRV75/38LV/4	(4kt.SW26)	BRV10
BRV75/37/12°/BV	–	BRV16
BRV75/38LV/4	(4kt.SW29)	BRV23
O-Ring 5x60	–	SI116
Conexiones atornilladas con un grosor de pared de hasta 50 mm.		
BRV75/48/4	–	BRV17
BRV-G140-23	d=1400 - 1500	BRV21
BRV-K140-24,5	d=1400 - 1500	BRV22
Otros		
BRV-AK	(Cuña de bloqueo)	BRV32

Dientes planos para Fresa Hidráulica

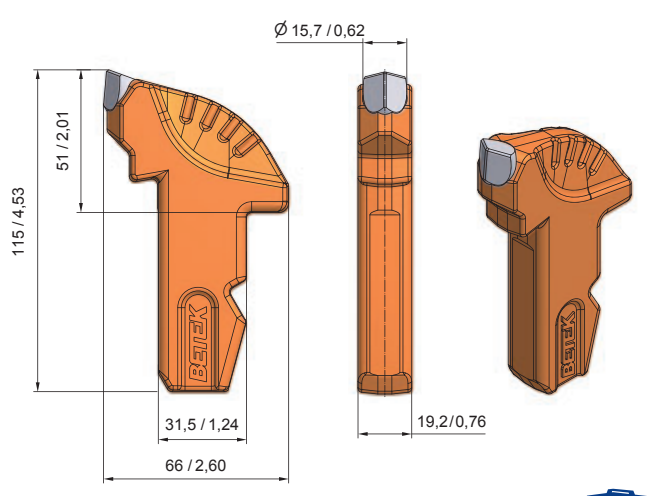

BF40
BF 115x32x19

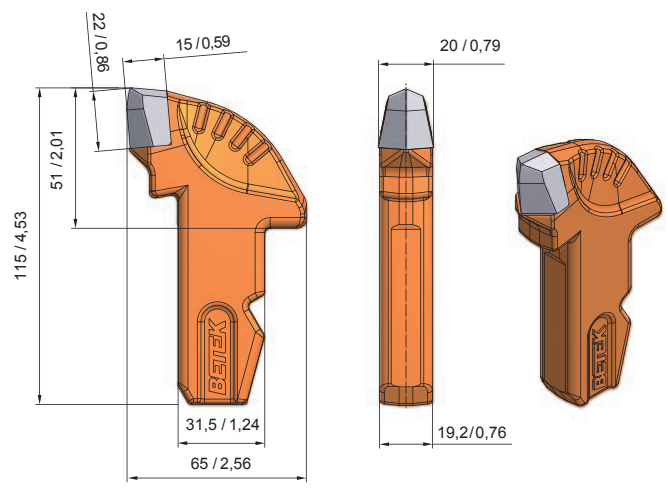

BF41
BF 115x32x19/1

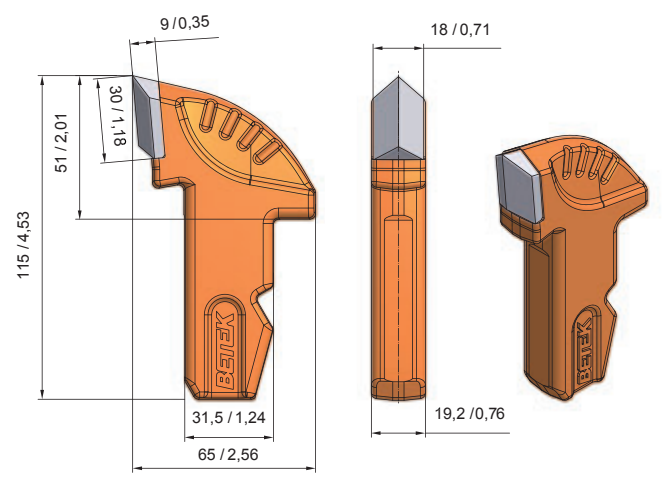

BF42
BF 115x32x19/2

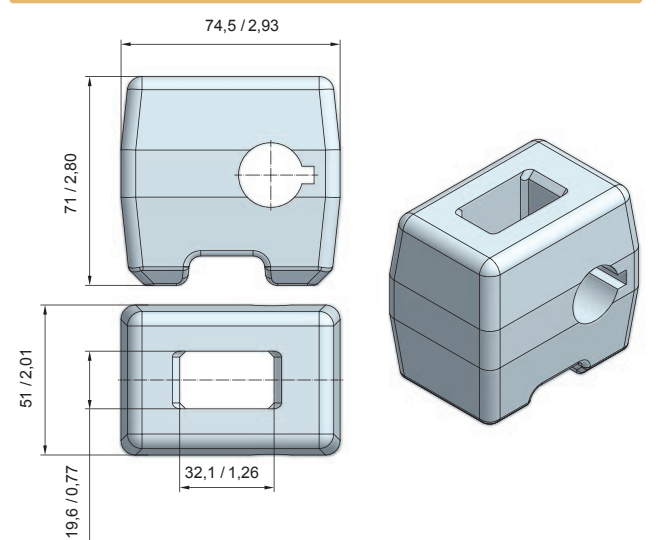

BHF15
BHF 32x20

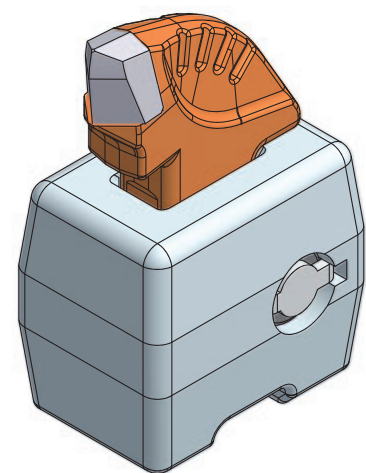
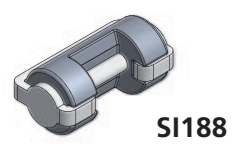

Perforación horizontal dirigida (PHD) Dientes soldados

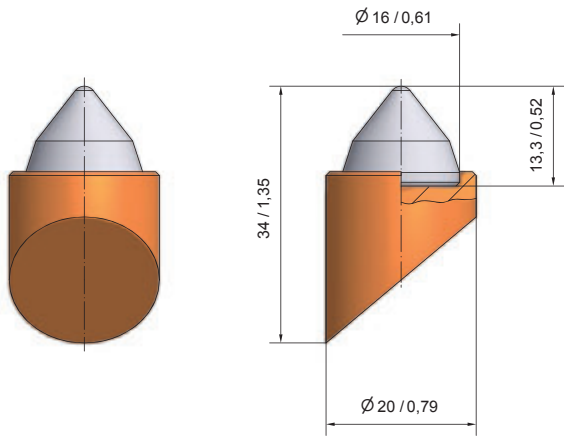

BFZ158
BFZ3 250

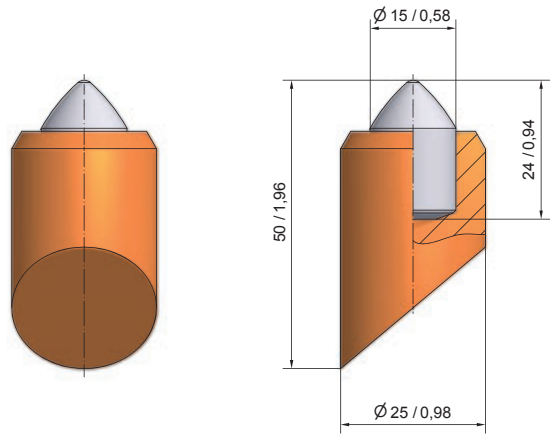

BFZ207
BFZ1 100

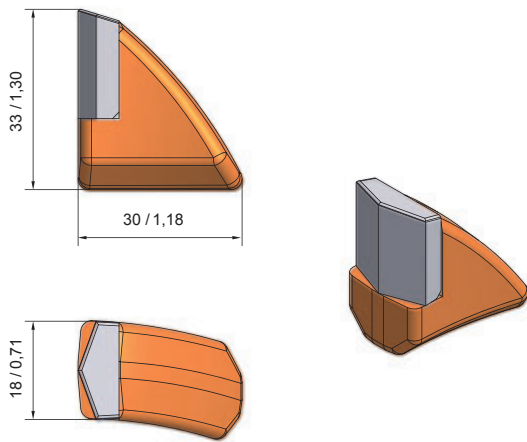

BFZ107
BFZ18/R 200

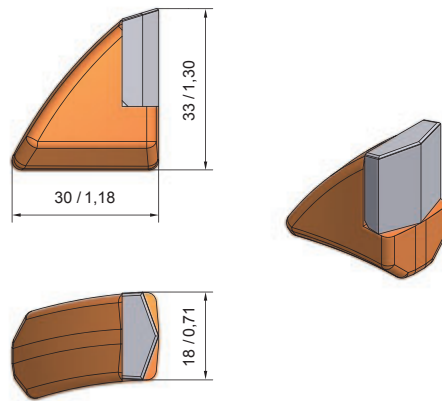

BFZ144
BFZ18/L 200

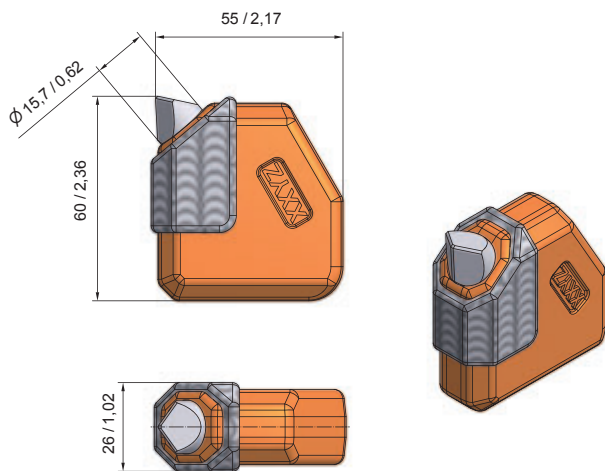

BFZ257
BFZ 60x55x22 25

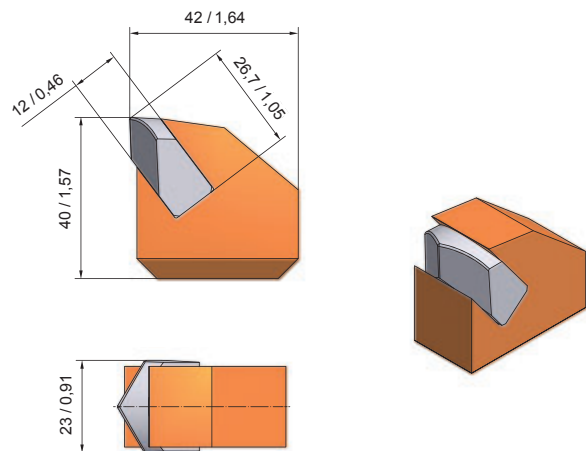

BFZ260
BFZ 42x40x23 50

Perforación horizontal dirigida (PHD) Dientes soldados

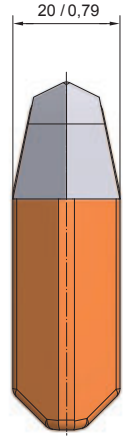
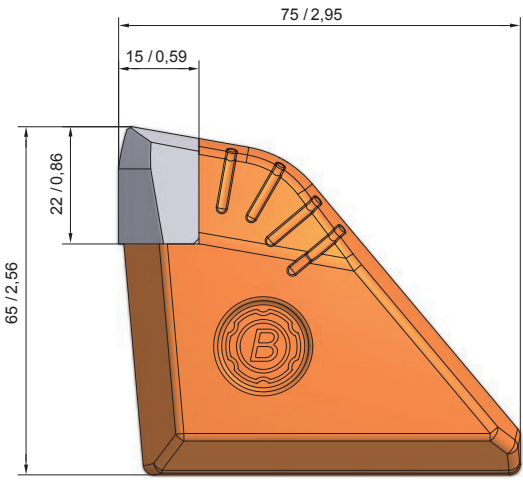
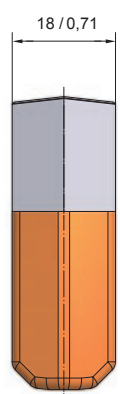
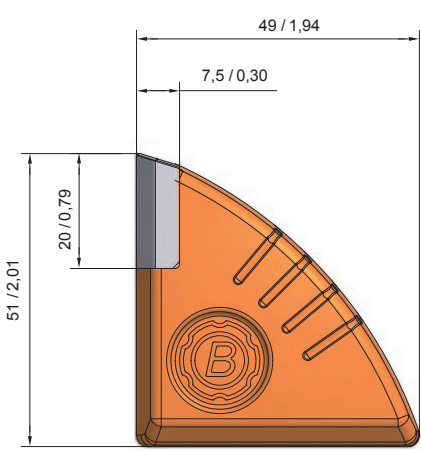

BFZ87
BFZ 18/2



BFZ319
BFZ 75x65x20

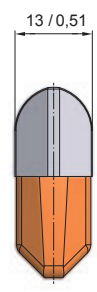
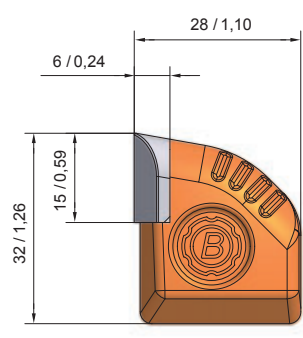
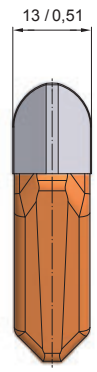
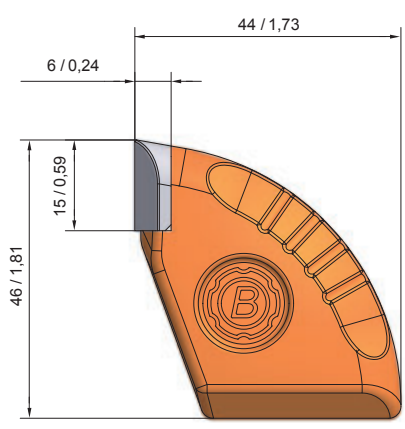

BFZ318
BFZ 46x44x13



BFZ321
BFZ 32x27x13

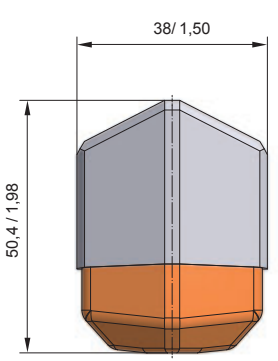
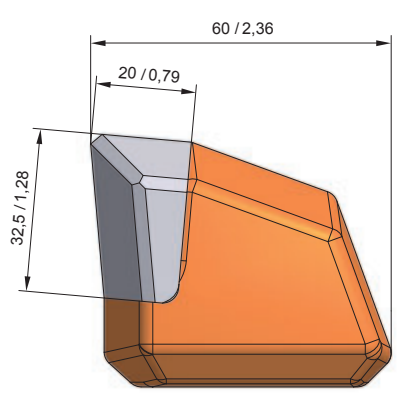
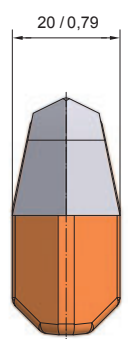
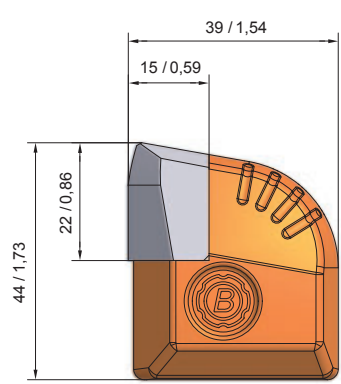

BFZ320
BFZ 44x39x22



BFZ35M
BFZ 38/M



Perforación horizontal dirigida (PHD) Brocas de vástago redondo

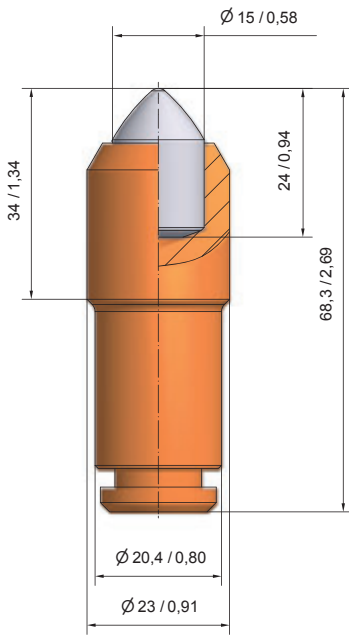

BSR187 
BG20X-15.2334

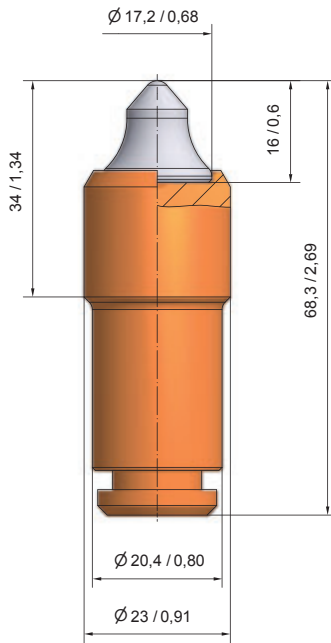

BSR186 
BG20X-62.2334

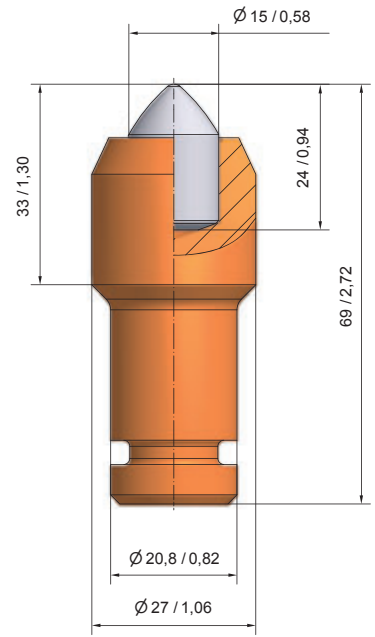

BSR93 
BG21X-15.2733

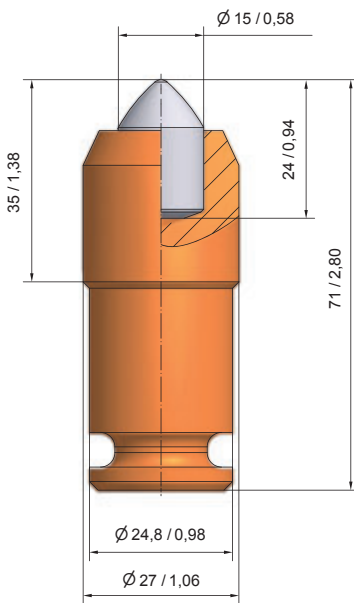

BSR115 
BG25X-15.2735

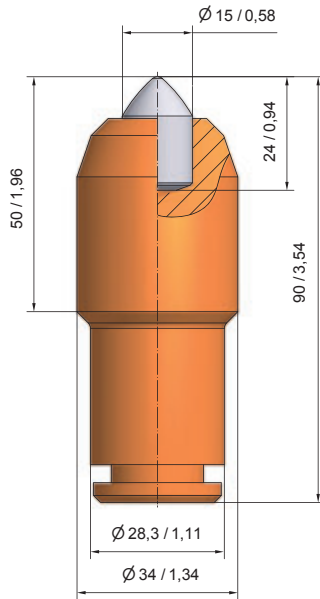

BSR110 
BG28F-15.3450

Protección contra el desgaste / TungStuds

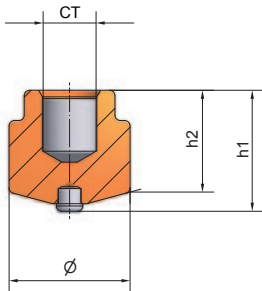

h₁: Altura antes de soldar
 h₂: Altura después de soldar

Informaciones adicionales:
www.betek.de/es/productos/tungstuds

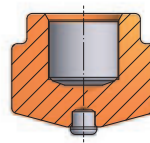
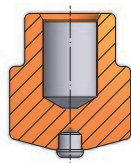
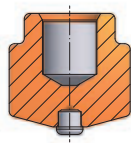

BTS01
 Ø: 16 mm
 h₁: 16 mm
 h₂: 11-12 mm
 CT: Ø7x8,4 mm

BTS02
 Ø: 16 mm
 h₁: 19 mm
 h₂: 14-15 mm
 CT: Ø7x11,4 mm

BTS03
 Ø: 19 mm
 h₁: 16 mm
 h₂: 10,5-11,5 mm
 CT: Ø9x8,4 mm

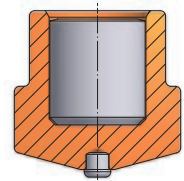
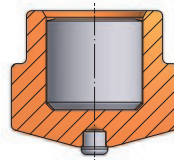
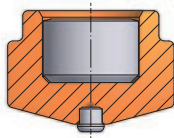
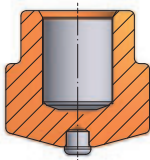

BTS04
 Ø: 19 mm
 h₁: 19 mm
 h₂: 13,5-14,5 mm
 CT: Ø9x12 mm

BTS05
 Ø: 22 mm
 h₁: 16 mm
 h₂: 10-11 mm
 CT: Ø12,6x8,4 mm

BTS06
 Ø: 22 mm
 h₁: 19 mm
 h₂: 13-14 mm
 CT: Ø12,6x12 mm

BTS07
 Ø: 22 mm
 h₁: 22 mm
 h₂: 16-17 mm
 CT: Ø12,6x14 mm



E

BETEK Bergbau- und Hartmetalltechnik
Karl-Heinz Simon GmbH & Co. KG

Sulgener Str. 19-23
D-78733 Aichhalden

Número del Servicio técnico + 49 (0) 74 22 / 5 65-591
Fax del Servicio técnico + 49 (0) 74 22 / 5 65-122

info@betek.de
www.betek.de

Distribuidores